



DR. BABASAHEB AMBEDKAR TECHNOLOGICAL UNIVERSITY, LONERE

At. Po. Lonere, Tal. Mangaon, Dist. Raigad 402 103 MS (www.dbatu.ac.in)

INVITATION FOR QUOTATION

Our Ref No.: DBATU/Civil Engg. /PA systems & Adjustable stand/2023

Date: 12/01/2023

19 JAN 2023

250

Quotation for Supply of PA systems & Adjustable Stand

Due On: 30/01/2023

Date of Opening: 31/01/2023

Time: 11.00 AM

To,

Sub: QUOTATION FOR THE SUPPLY OF PA systems & Adjustable Stand

Dear Sir,

Your quotation for the items listed overleaf, may please be submitted to the under signed, so as to reach this Office not later than 30/01/2023. While submitting your quotation, the following procedure may please be observed and other points borne in mind.

01. The maker's name must be specified.
02. The "Terms and Conditions" for supply and delivery of stores, should be clearly indicated in the quotation, stating whether rates are, inclusive of all taxes, Packing and forwarding charges Freight charges, etc. or not, however rates offered as including all taxes will be more welcome.
03. If packing and forwarding charges are to be charged separately, it should be so clearly stated in your quotation.
04. Please mention clearly whether consignment would be Ex-Godown, Ex-Shop, or F.O.R. dispatching stations. Preferably terms offered as "Delivery of consignment of stores, on F.O.R.
05. Envelope should be clearly marked with our reference No and date of this quotation. It should also be superscripted as per the format given above.
06. The quotation would be opened as per date and timing given above, if desired by you, you may depute an authorized representative with a letter of authority to be present at the time of opening of the quotation at this Office on the aforesaid day, date & time.
07. Your quotation must be valid for a minimum 30 (Thirty) working days from the date of its opening.
08. Quotation received after the date of opening may not be taken into consideration.
09. Items tendered should confirm to the specification shown in the attached list when and where, full or no specifications are indicated against items in the list. Kindly furnish your full specification in accordance with accepted standards against each item tendered. Where reference to catalogue is made, the relevant catalogues/ Pamphlets/ Literature should accompany the quotation.
10. Your quotation should be for all new items and not for second hand and should be submitted as per standard format of Quotation Submission attached herewith.
11. Please state whether items will be available Ex-Stock. If not the minimum period for delivery, or for supplying the items or stores.
12. It should be clearly stated whether **GST, Insurance, Freight or packing** and forwarding charges, or any other taxes and duties, etc. leviable.
13. It would be appreciated if illustrated catalogues/Literature etc is furnished with the quotation.

14. Expression to as "Complete with standard Equipment" complete with standard accessories "Equipment to" As good as should be avoided. If at all their use is unavoidable then it should be very specifically indicated as to what exactly they mean and what exactly would be supplied under them. Any ambiguity or vagueness should be avoided.
15. For convenience, kindly adopt while quoting the same serial Nos. as given in the list detailed below.

Thanking You.

Yours faithfully,



Registrar

Dr. Babasaheb Ambedkar Technological
University,

List of Items

Sr. No.	Description / Specification	Make	Approx. Qty.
01	Technical Specifications of <i>Portable PA systems & Adjustable Stand</i> are attached as a separate sheet	-	-

Annexure

Detailed Technical Specifications	Approximate Qty
<p>Portable Speaker- 1 No</p> <p>Elegant and stylish looking plastic moulded cabinet with Trolley System. Two Mic inputs, Two Wireless Mics, one Aux input & one Music input. Built-in 305 mm (12") 4W speaker & 8W HF driver. Mic 1 has selectable priority over all other inputs. Built-in MP3 Player with Bluetooth, Recorder and remote control. Built-in Digital Echo. Active Bass & Treble controls. LED indications for low battery, charging & clip output. Facility of auto cut-off to prevent battery from deep discharge. Three power source operation (AC mains, External 12V DC or built-in 12V 7Ah rechargeable battery)</p> <p>Amplifier Receiver: BTA 880 Speaker: 1x12" Speaker, 1xHF Driver Power Output (BI-Amp): 50W Max. (LF+HF) LF: 35W Max HF: 15W Max Input Channels: 2 x Mic 3mV/4.7kΩ, 1 x Aux 100mV/47kΩ, 2 x Wireless MIC Frequency Response: 55-18,000Hz ±3dB (Bi-Amp) S/N Ratio: 60dB Tone Controls: Bass ±5dB at 100Hz, Treble ±5dB at 10kHz Digital Player: MP3 player with USB, SD, MMC card reader, Recording function and Bluetooth Preamp Output: 200mV/600Ω Protections - AC Fuse: 1 Amp. 250V (T 1A L) Power Supply-AC: 220V-240V 50/60Hz, DC: 12V Car Battery (external), 12V 7Ah Rechargeable battery (built-in) AC Power Consumption: 60VA Dimensions: W405 x H610 x D350 mm Weight: 18.80 kg</p> <p>Transmitter Wireless Microphone: 2 x Hand Held Frequency Stability: ±0.005% Max. Modulation: 45dB RF Output: 10mW Frequency Response: 50-15,000Hz Battery: 3V (4 × 1.5V AA Pencil Cells); Current Consumption < 200mA Dimensions: Ø52 × L242 mm, Weight (w/o battery): 140g</p>	<p>01</p> 
<p>Portable Speaker (PA20 Watts_WM-22) – 2 No</p> <p>A truly portable, highly versatile and attractive 20 Watts Max. PA Wireless Amplifier Set WP-220M. Ideal for various Indoor and Outdoor applications such as Small Gatherings, Presentations, Performances, Bus Tours, Classrooms etc., Should be Supplied with Handheld wireless microphone model WM-22 It should be supplied with Built-in digital MP3 player & recorder, Bluetooth facility, Digital echo effects provided. Wired Mic as input. It should have provision for connecting one wired microphone & an AUX source like a CD player or Mixer using 3.5mm phone jack. Tone control should be provided for adjusting the tone settings. It should Operates on AC mains, 12V external car battery & 12V 1.2Ah internal rechargeable lead acid battery. It should have Facility for recharging a 12V 1.2Ah internal battery and 8.4V rechargeable battery for handheld transmitter. 8 Ohm speaker output for connecting an external speaker.</p> <p>Amplifier Audio Output 20W Max. Input Channels Sensitivity Mic 6mV, Aux 200mV AUX Output 400mV Tone Controls Bass: ± 6dB at 80Hz Treble: ± 6dB at 8kHz USB/SD Player MP3 and WMA format Power Requirements AC 220-240V, 50/60Hz DC 12-15V Car Battery, 12V 1.2Ah Rechargeable Battery Power Consumption AC: 35W, DC: 2A Protection DC Fuse T 3A/250V Wireless Receiving Mode Quartz Controlled Fixed Frequency Wireless Range Over 20m in Free Space (Line of Sight) Dimension W200 × H295 × D122 mm Weight 2.60kg</p> <p>Transmitter WM-22 RF Output Power 10mW (Max.) Max. Modulation 45dB</p>	<p>02</p> 

R

<p>Frequency Response 50-15,000Hz Battery 1 × 9V Battery Dimension Ø52 × 1.242 mm Weight 150g (without battery)</p>	
<p>Portable Speaker (PA20 Watts_WM-23) – 2 No A truly portable, highly versatile and attractive 20 Watts Max. PA Wireless Amplifier Set WP-220M. Ideal for various Indoor and Outdoor applications such as Small Gatherings, Presentations, Performances, Bus Tours, Classrooms etc., Should be Supplied with Headband microphone WM-23 available in different frequencies. It should be supplied with Built-in digital MP3 player & recorder, Bluetooth facility, Digital echo effects provided, Wired Mic as input. It should have provision for connecting one wired microphone & an AUX source like a CD player or Mixer using 3.5mm phone jack. Tone control should be provided for adjusting the tone settings. It should Operates on AC mains, 12V external car battery & 12V 1.2Ah internal rechargeable lead acid battery. It should have Facility for recharging a 12V 1.2Ah internal battery and 8.4V rechargeable battery for handheld transmitter. 8 Ohm speaker output for connecting an external speaker.</p> <p>Amplifier Audio Output 20W Max. Input Channels Sensitivity Mic 6mV, Aux 200mV AUX Output 400mV Tone Controls Bass: ± 6dB at 80Hz Treble: ± 6dB at 8kHz USB/SD Player MP3 and WMA format Power Requirements AC 220-240V, 50/60Hz DC 12-15V Car Battery, 12V 1.2Ah Rechargeable Battery Power Consumption AC: 35W, DC: 2A Protection DC Fuse T 3A/250V Wireless Receiving Mode Quartz Controlled Fixed Frequency Wireless Range Over 20m in Free Space (Line of Sight) Dimension W200 × H295 × D122 mm Weight 2.60kg</p> <p>Transmitter WM-23 RF Output Power 10mW (Max.) MAX. Modulation 45dB Frequency Response 50-15,000Hz Battery 3V Dimension L65 x W35 x H105 mm Weight 90g (without battery)</p>	<p>02</p> 
<p>Adjustable Stand for Samsung LED Display – 1 No Mounting Type - Floor Mount Movement Type - Tilt Brand - Store2508 or Equivalent Material- Metal LED Display Size - 55 Inches</p> <p>Excellent durability - Stand on wheels should be made from solid metal with a powder-coated finish. The frame should be strong and heavy duty and can support most of 32" to 75" LED flat screens or monitor weight up to 50 kgs</p> <p>Adjustable Height - Flat screen mobile tv stand max height is 67" from the floor to top shelf. LED display with 3 level adjustable height from 42.5" to 59" in 4-inch increments. stand with mount able to tilt up/down -15 to +15 degree for best viewing angle and to reduce glare</p> <p>Portable - TV trolley floor stand equipped with four large heavy-duty casters to move the TV to anywhere you want easily. The caster's can also be locked allows the cart to be stationary or mobile as required. The wheels can move on carpet as well as wooden floor and other rough ground. Tall tv stand with shelves should be ideal for, office, school studio, Seminar Hall.</p> <p>Two floating shelves - Mobile tv stand on castors with two metal floating shelf for holding Blu-ray player, AV equipment DVD player, Speaker, Games Consoles</p> <p>Easy assemble - Floor standing television stand is easy to assemble. Large rolling tv stand comes with all the mounting bolts, spacers, washers and instruction manual that you need to fit any flat-panel TVs</p>	<p>01</p>

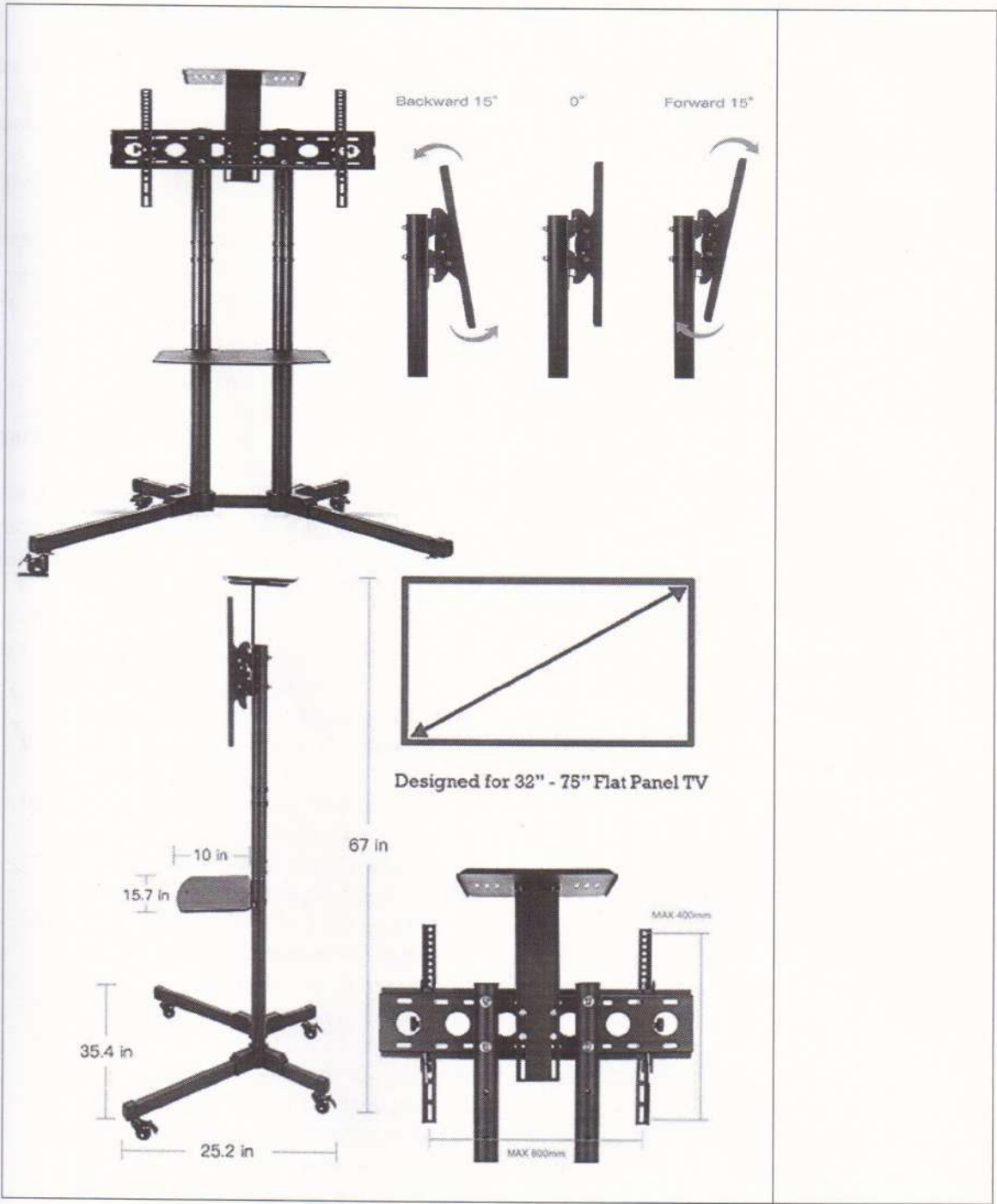

Technical Specifications Shown above are checked and verified by the Technical Committee of the Department

[Signature]
 Head, DoCE