

**DR. BABASAHEB AMBEDKAR TECHNOLOGICAL UNIVERSITY, LONERE –
RAIGAD -402 103
Mid Semester Examination – October - 2017**

Branch: Electrical/Electronics/Computer/IT **Sem.:- I**
Subject with Subject Code:- Basic Electronics Engineering (EXE105) Marks: 20

Solution/ Model Answer/ Marking Scheme

Q. 1.
I. d), II. b), III. b), IV. a), V. b), VI. d

Q. 2.
a) i) Concept and description 03 marks
ii) Examples 03 Marks

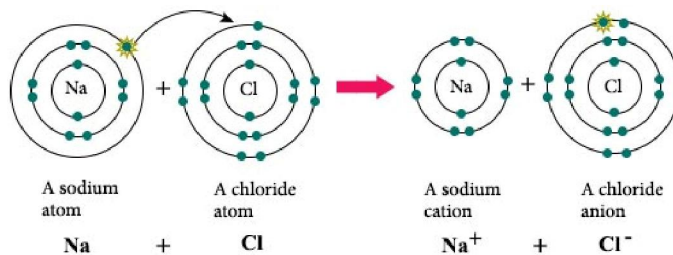

Figure: Example Ionic bond

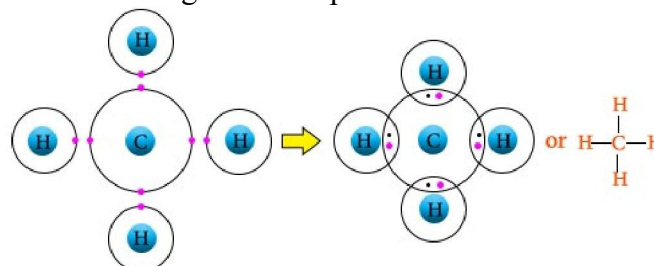

Figure: Example Covalent bond

b) i) Concept and description 03 marks
ii) Examples with neat sketch 03 Marks

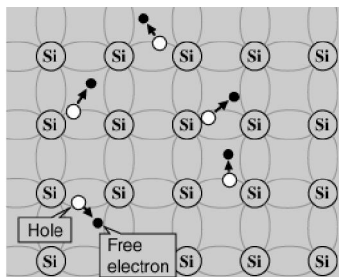

Figure: Lattice structure for intrinsic

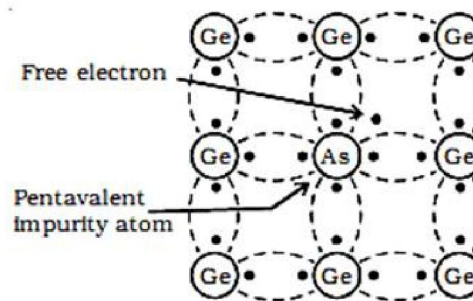
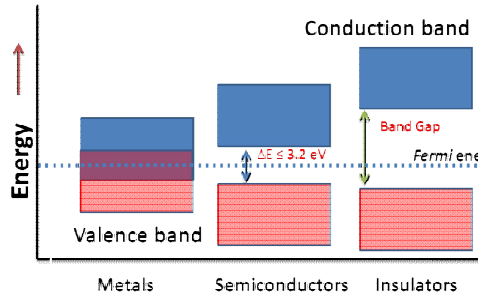

Figure: Lattice structure extrinsic

Q. 3.

- a) i) Concept and description 02 marks
 ii) Neat sketch 02 Marks



- b) i) Concept and description 02 marks
 ii) Neat sketch 02 Marks

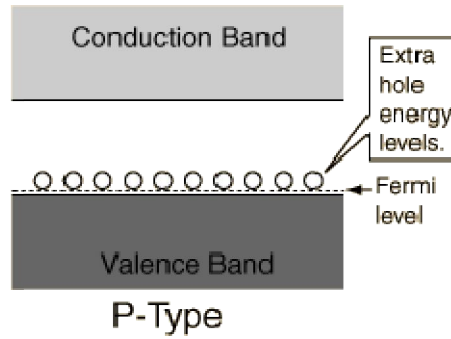

- c) i) Concept and description 02 marks
 ii) Neat sketch 02 Marks

